

Rigid Inflatable Boat

# GOLDEN LINE

Models:

## G850

User's Manual

**CONTENTS**

	page
<b>INTRODUCTION</b>	<b>3</b>
<b>PURPOSE</b>	<b>3</b>
<b>TECHNICAL DATA SPECIFICATION</b>	<b>4</b>
<b>COMPLETE SET</b>	<b>5</b>
<b>INFLATION / DEFLATION VALVES OPERATION</b>	<b>8</b>
<b>PREPARATION FOR EXPLOITATION</b>	<b>9</b>
<b>STEERING CONSOLE INSTALLATION</b>	<b>9</b>
<b>CONTAINER INSTALATION</b>	<b>10</b>
<b>MAINTENANCE</b>	<b>10</b>
<b>OPERATING REGULATIONS</b>	<b>11</b>
<b>ANNEX</b>	
Wiring diagram	
Water sypply system	
WC and severage diagram	

**INTRODUCTION.**

"GRAND" inflatable motor boat of the "GOLDEN LINE" series G850 has been designed under requirements of Directive 2013/53/EU and manufactured by Grand Marine Corporation.

This manual has been compiled to help you to operate your craft with safety and pleasure. It contains details of the craft; the equipment supplied or fitted, its systems and information on their operation. Please read it carefully, and familiarize yourself with the craft before using it.

**PURPOSE.**

The rigid inflatable motor boat of the "GOLDEN LINE" series relates to the category of recreational craft and is intended for water sports, tourism and leisure purposes.

## TECHNICAL DATA SPECIFICATION

Model	Unit	G850
Length overall	m <b>ft-inches</b>	8.5 <b>27'11"</b>
Length inside	m <b>ft-inches</b>	6.4 <b>21'</b>
Width overall	m <b>ft-inches</b>	2.95 <b>9'8"</b>
Width inside	m <b>ft-inches</b>	1.75 <b>5'9"</b>
Tube diameter max	m <b>ft-inches</b>	0,6 <b>24"</b>
Number of chambers		5
Passenger capacity	pers.	12
Load capacity	kg <b>lbs</b>	2000 <b>4576</b>
Boat weight	kg <b>lbs</b>	1200 <b>2640</b>
Engine power recommended	HP <b>kW</b>	300 <b>220.6</b>
Engine power max	HP <b>kW</b>	400 <b>294.2</b>
Engine weight max	kg <b>lbs</b>	490 <b>1078</b>
Engine shaft length (L-long, XL-ultralong)		<b>30"</b> (Ultralong)
Boat design Category(RCD 2013/53/EU)		B
Fuel tank capacity	lt	300
Water tank capacity	lt	100
Waste water tank capacity	lt	40

**COMPLETE SET**

Description	set	Description	set
<p><b>STANDART FEATURES</b></p>		<p><b>OPTIONAL EQUIPMENT</b></p>	
<p>Heavy-duty Deep-V handlaid polyester hull.</p>	<input type="checkbox"/>	<p>Keel protection package.</p>	<input type="checkbox"/>
<p>Bow lockers with anchor compartment and hatches.</p>	<input type="checkbox"/>	<p>Tube protection package.</p>	<input type="checkbox"/>
<p>Bow step plate with nav. lights and 2 cleats.</p>	<input type="checkbox"/>	<p>Overall cover.</p>	<input type="checkbox"/>
<p>Steering console CL-21 with front lifted seat, windshield, railing and gloves box.</p>	<input type="checkbox"/>	<p>Console cover.</p>	<input type="checkbox"/>
<p>Driver's double seat SD-21 with two folding seats.</p>	<input type="checkbox"/>	<p>Double seat cover.</p>	<input type="checkbox"/>
<p>U-form rear seat (sofa with 2 side lockers, soft cushions and high seatback).</p>	<input type="checkbox"/>	<p>Collapsible stainless steel bimini top.</p>	<input type="checkbox"/>
<p>Rear railings, 2 rear cleats and 2 towing eyes.</p>	<input type="checkbox"/>	<p>Hydraulic steering system.</p>	<input type="checkbox"/>
<p>Rear locker with large access door and gas springs.</p>	<input type="checkbox"/>	<p>Rear sundeck with cushions.</p>	<input type="checkbox"/>
<p>Build-in 300-lit. fuel tank with filler and send.</p>	<input type="checkbox"/>	<p>Water shower set with 100-lit. tank, pump, shower.</p>	<input type="checkbox"/>
<p>Electric package (navigation light, bilge pump, electric horn, switches, battery switch and complete wiring)</p>	<input type="checkbox"/>	<p>Washdown system with 40-lit. tank.</p>	<input type="checkbox"/>
<p>Maintenance kit , pump, 2 paddles and manual.</p>	<input type="checkbox"/>	<p>PVC teak decking.</p>	<input type="checkbox"/>
<p><b>GRAND LUXE FEATURES</b></p>		<p>SILVERTEX upholstery upgrade.</p>	<input type="checkbox"/>
<p>Two rear rope hatches</p>	<input type="checkbox"/>	<p>Overpressure valve.</p>	<input type="checkbox"/>
<p>Stainless steel bow railing.</p>	<input type="checkbox"/>	<p>Removable table with 4 cup holders.</p>	<input type="checkbox"/>
<p>Two swim platforms with folding ladder.</p>	<input type="checkbox"/>	<p>Isoterm fridge DR65</p>	<input type="checkbox"/>
<p>Waterski towing arch with top for G850</p>	<input type="checkbox"/>	<p>Electric anchor with lifting mechanism</p>	<input type="checkbox"/>

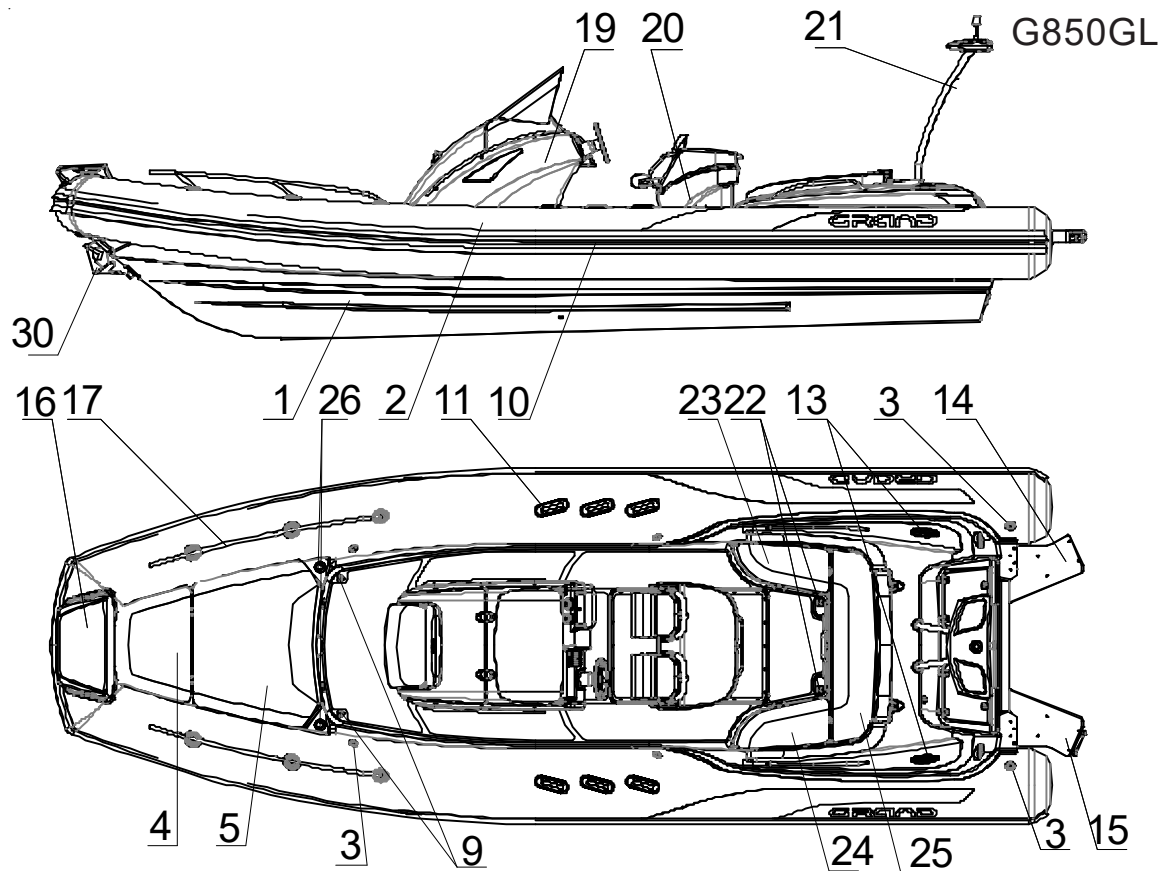

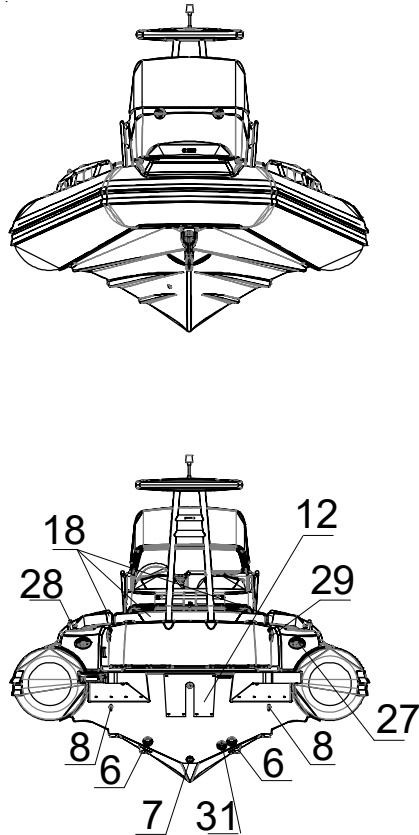

Pos	Item
1	Fiberglass hull
2	Rainforced buoyancy tube
3	Inflation / deflation valve
4	Anchor hatch with cushion
5	Bow hatch with cushion
6	Drain valve
7	Sump plug 20mm
8	Rear lifting eye
9	Bow lifting eye
10	Rubbing strake with splash guard
11	Safety handle
12	Motor plate external
13	Pull-up cleat 8'
14	Swimming platform
15	Swimming platform with folding ladder
16	Bowstep plate
17	Stainless steel bow railing
18	Rear seat back
19	Steering console CL-21
20	Container SD-21 with cushions, soft backs
21	Waterski towing arch with top
22	Expanded drain plug
23	Rear locker removable cushion
24	Rear locker removable cushion
25	Rear sofa cushion
26	Cupholder
27	Rear waterski towing eye
28	Rear seat extended handrails
29	Fuel filler neck
30	Anchor
31	Drain valve water system

## INFLATION / DEFLATION VALVES OPERATION

The inflation/deflation valve is intended for:

- filling the compartment with air from a standart pump or filling system and maintaining pressure in the tube for prolonged time,
- adjustable drop of pressure in compartment.

The air fill valve is designed as a tab-type non-return valve.

Every inflation / deflation valve includes the following parts : valve body 1, valve nut 5, valve cap 2 with strap 3, washerwith gasket 4, spindel 6 with spring 7, cup diaphragm 8 ( Fig.1).

**INFLATION MODE** : valve is closed with gasket 4 tight . To move the valve to deflation mode : push the button 6 and turn it clockwise to fix it in lower position

**DEFLATION MODE** : button is fixed in lower position. To move the valve to inflation mode : push the button 6 and turn it counter clockwise. The button goes to upper position.

### ATTENTION !

1. *Overinflating of your boat, when the air pressure is more than nominal, sufficiently decreases the boat life time.*
2. *The valves are airtight just in case they are closed with the caps tight.*
3. *The tube is airtight in case it keeps its form for 8 hours at least.*

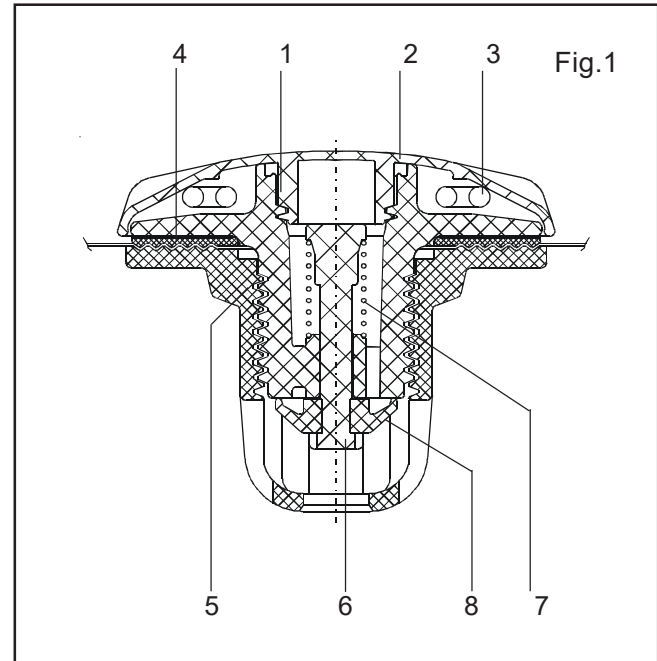



## PREPARATION FOR EXPLOITATION.

In order to set the boat in operation condition perform as follows:

- unfold the inflatable tube;
- mount outboard engine on the transom in accordance with it's own installation instruction.
- extend engine remote control cables and steering cable from engine mounting place to steering console mounting place through holes on the deck and helm stowage.

## STEERING CONSOLE INSTALLATION

In order to install the windscreen onto console perform the next operations ( Fig. 2 ):

- align the windscreen holes with holes on console overhead part;
- fix windscreen by means of screws M6x30, bushes #1, bushes #2, serrated lock washers, washers and nuts M6 from the complete set;
- tighten all nuts.

In order to install the windscreen railing onto console perform the next operations ( Fig. 2 ):

- align holes in the windscreen railing supports with holes on console overhead part;
- fix windscreen railing by means of bolts M8x30, serrated lock washers and washers from the complete set;
- tighten all bolts.

In order to install the steering console, perform the next operations ( Fig. 2 ):

- open the front seating;
- align console bottom holes with holes in the deck surfaces and fix console to deck by means of bolts M6x30, serrated lock washers and washers from complete set;
- close front seating.

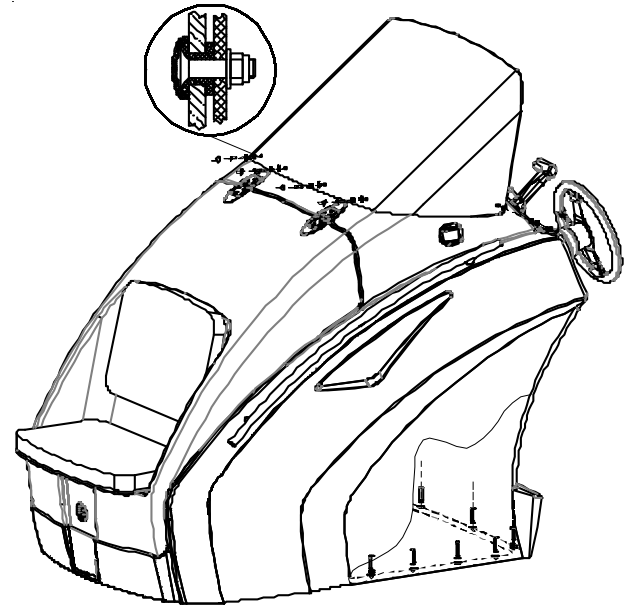

Fig.2

**ATTENTION !** To avoid the water penetration into the console inner layers, please, tight all the hole free space with any water resistant filler.

**CONTAINER INSTALATION**

In order to install container onto deck perform the next operations ( Fig. 3):

- open hatch of the back locker;
- align bottom container holes with holes on the deck;
- fix container by means of bolt M8x30, serrated lock washers, washers from the complete set;
- tighten all bolts;
- replace hatch of the back locker.

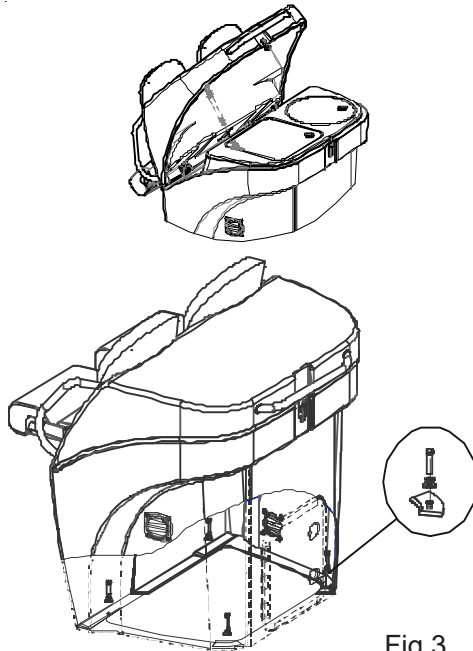

Fig.3

**MAINTENANCE**

Main conditions of long service life is right and careful service.

- Avoid excessive increasing of pressure in the board, especially from heating by the sun rays.
- After exploitation take off sand and dirt from boat surface, and carefully dry it.
- Avoid the water getting into the chambers. If a fuel or an oil / gas gets to the boat surface it is necessary to wash the soiling place by soap water as soon as possible and dry.
- Pay attention to the condition of bottom and seat surfaces. If the coating is destroyed it is necessary to dry this element and restore the defend ply.
- After the season prepare the boat to winter keeping. Clean boat surface from sand and dirt and make the necessary repairs, if damages take place. If it is possible, keep the boat in the open and slightly pumped state in air temperature 0-25°C. The boat must be protected from the sun rays.
- Insignificant boat repairing (eliminating the board punctures or cuts) you may carry out by yourself. In this case use the coated fabric patches from the complete set. Ask your dealer for the correct type of glue you may use for the repair.
- We use only top quality stainless steels, which are resistant to corrosion. However, it is not permanent and maintenance is required:
  - Avoid contamination and scoring its surface,
  - Frequently wash with fresh water,
  - Grease and mirror polish it regularly.
- In case if sufficient damages of hull, tube body, partitions or seams it is recommended to apply for professional repair in authorised service station.

## OPERATING REGULATIONS

Dear user,

We thank you for your purchase and do hope that you will have a great fun of it. However, to make your joy and pleasure complete, we would request you to read carefully and observe the directions and recommendations specified below.

### IT IS STRICTLY FORBIDDEN :

to handle the boat in the state of intoxication and without individual rescue means being used (life-saving belts, jackets, etc.)

### IT IS FORBIDDEN :

- to overload the boat above the design weight-carrying capacity;
- to use an outboard engine of power exceeding the maximum allowable value;
- to bring the tube pressure up to the value exceeding the rated one ( 0.15 bar/ 2.15 psi );
- to drag the boat across a rough surface.

### ■ Danger of usage of engine having insufficient or excessive power

According to the safety regulations, each inflatable boat should be furnished with an outboard engine having the maximum allowable power. You will find the data on the maximum allowable power of the engine on the manufacturer's plate with the designation of the model type inscribed thereon. The plate is fixed in the afterbody of the boat. However, you should choose the engine power within the allowable range so as to ensure that you may safely reach the shore when heading into the wind or into the current.

### Observation of local shipping regulations

For each particular water area the local shipping regulations are in force. You may apply for information to the appropriate water transport and shipping directorate, as well as to the water police.

### ■ Proper usage of boat equipment and accessories

Use the boat equipment and accessories only on their direct purpose to ensure reliable service.

### ■ Availability of Oars

Even when sailing with an outboard engine you should always have the oars available with you so that you were able to reach the shore without outside assistance in case of any damage to the boat.

### ■ Usage of emergency stop switch

On your request any outboard engine seller may provide your engine with the emergency stop switch. During navigation the switch should be connected to the wrist of your hand by means of a cord. In case you fall overboard, even if being a steersman, the switch will cut out the engine and the propeller. This arrangement will enable you to avoid any traumas and to reach the boat.

### ■ Prevention of damages caused by electrolyte or fuel leakages

Take all possible precautions against penetration of fuel or electrolyte from the storage battery into the inflatable boat. If it does happen wash thoroughly the fouled spots with water.

### ■ Cargo arrangement and stowing, attachment of items and prevention of falling overboard

You should be always sure that the number of people on board never exceeds that specified in the user's manual or on the manufacturer's plate provided on the transom. The boat will retain an adequate floatability and will not keel over only provided that the load is arranged reasonably. Therefore, do not accommodate all passengers on the same side of the boat. Arrange the cargo to be carried uniformly inside the boat, all items being reliable secured on the bottom of the boat. All passengers should be accommodated inside the boat. The occupied seats should not be left throughout the entire sailing time. When sailing with an outboard engine the steersman should shift his body forward in the course of

acceleration to prevent the boat forebody from raising under the force of upthrust waves.

#### ■ **Presence of sharp and pricking objects on board**

Despite the strong shell of the boat we are recommended to handle sharp and pricking objects being on board with care. For example, it concerns a knife blade, fish-hook point, etc.

#### ■ **Rocky shore, mole, shoals (for example, sand banks, coral reefs, rocks)**

Approach rocky shores, shoals, moles, etc. carefully to avoid damages to the boat. It is strictly prohibited to drag the boat across rough surfaces (shingle, rocks, concrete, etc.).

#### ■ **Check at navigation**

In case of prolonged navigation with the use of an outboard engine, regularly check to ensure that the engine is reliably attached to the boat. If the engine was attached carelessly the attachment may work loose under the action of vibration.

Besides, check air chambers pressure at regular intervals, since the pressure may vary under the effects of outside air temperature and atmospheric pressure variations.

Never forget to monitor regularly the quantity of fuel in the fuel tank. Keep always in mind that the quantity of fuel should be sufficient for you to sail to your final destination.

#### ■ **Availability of rescue means (life-saving jackets, distress signals, spare parts)**

If you are planning to go beyond the protected water areas you should provide all passengers on board with life-saving jackets. Those passengers who cannot swim should always carry the life-saving jackets while on board! It is also recommended to keep constantly distress signal means on board.

#### ■ **Towing**

At towing the towing rope length should not be at least 3 lengths of the boat, the rope being secured to both boats in a manner ensuring its immediately, single-motion release. The steersman of the towed boat should be assisted by another

crew member to monitor the process of towing. In this case, certain communication gestures should be agreed upon beforehand.

#### ■ **Damage to one of air chambers**

The inflatable boat is designed to provide an adequate stability in case of the complete damage to one the air chambers (balloon compartments) at the expense of the remaining air chambers and the hull. Thanks to it, you will be able to reach safely the nearest shore. Reduce the speed and shift your body to the undamaged part of the boat. Watch changes in stability. After this immediately head for the nearest shore. To prevent penetration of water into the boat, pull the shell of the damaged air chambers upwards.

#### ■ **Anchor and mooring fast fastening**

Fix the anchor and towing ropes in the forebody of the boat to the front towing ring. Fix the back spring on the transom via special holes.

#### **Danger of currents and wind**

Before navigation of the boat in unfamiliar waters make detail inquiries about local conditions and regulations! Currents, wind, shoals, rising and falling tides, as well as weather variations may imply serious danger!

#### ■ **In emergency stay in boat**

In any unexpected situation (engine failure, boat damage, etc.) do not ever leave the boat provided it is still afloat. Even if you believe that the shore is just nearby stay in the boat, since you will be looked for in this particular place and, most probably, will be found. Should the boat become partially flooded throw heavy objects (batteries, fuel tank, engine) overboard to ensure additional floatability.

The "GRAND" Company employees would like to wish you a pleasant and safe leisure time!

WIRING DIAGRAM

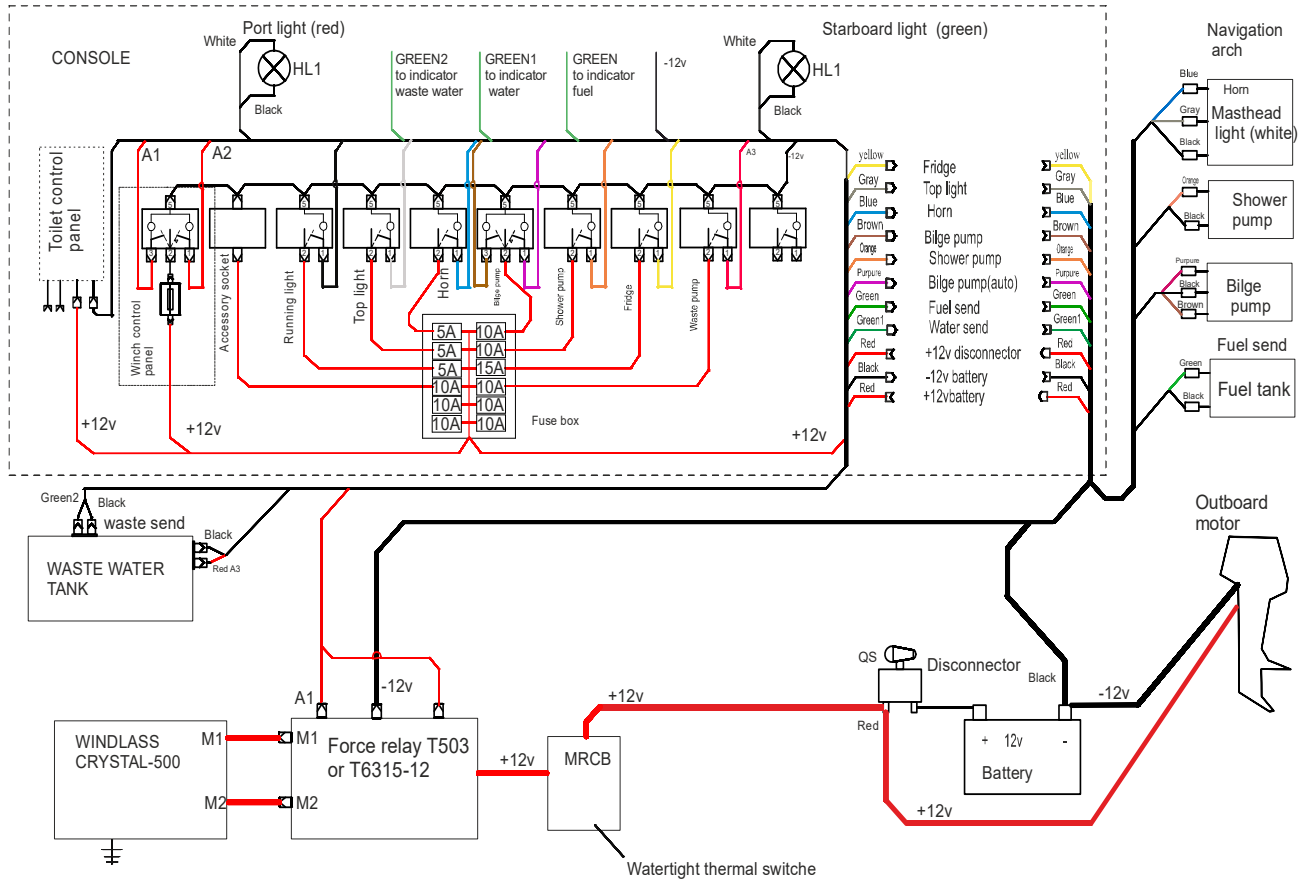

## Water supply system

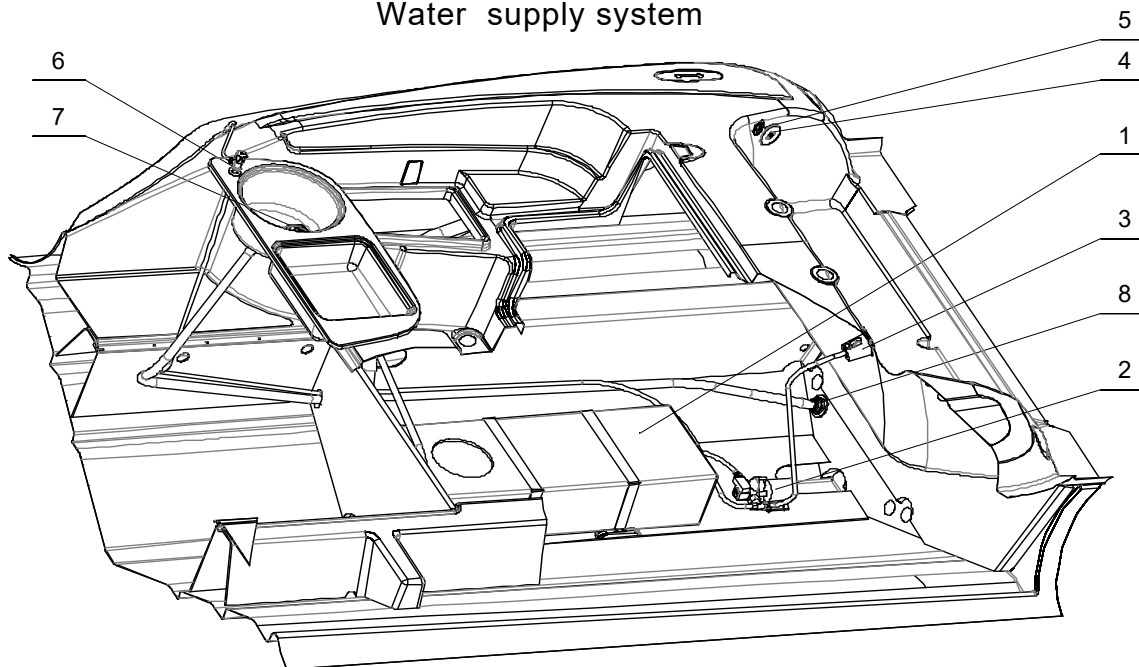

Pos	Item	Pos.	Item
1	Water tank	5	Dump valve
2	Water pump	6	Water tap
3	Shower container	7	Wash-bowl output
4	Deck filler	8	Surplus valve

### WC and sewerage system

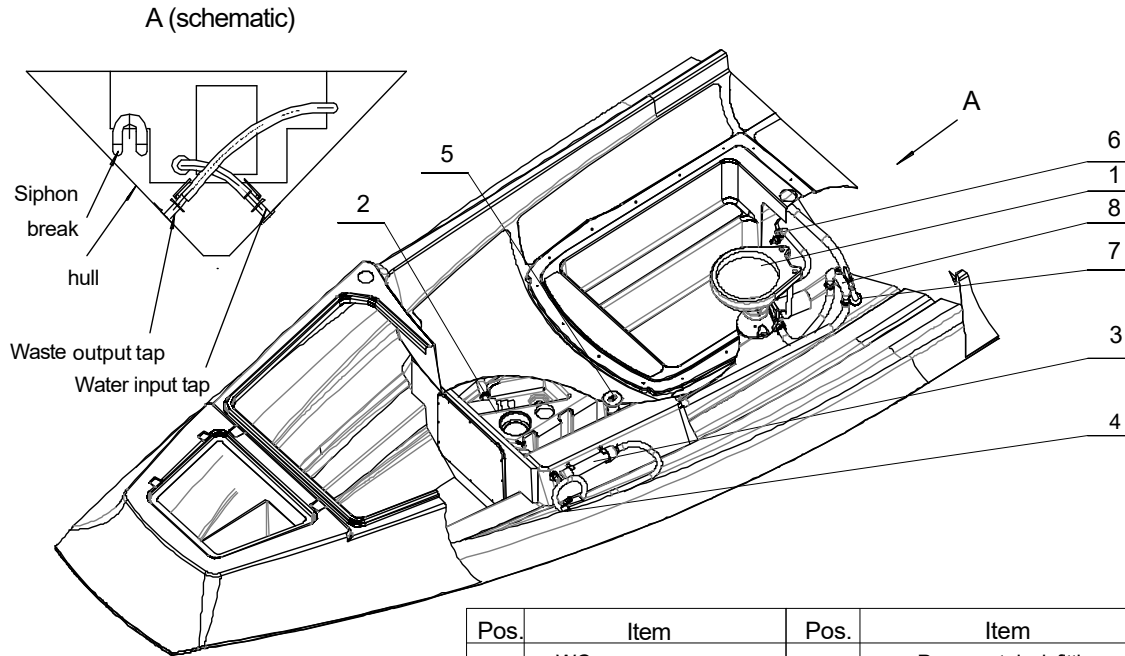

Pos.	Item	Pos.	Item
1	WC	5	Pump-out deck fitting
2	Waste retention tank	6	Water input tap
3	Drainage filter	7	Overboard discharge valve
4	Dump valve	8	Siphon break